



record system 20

User manual

Document identification

Article nr.: 102-020110469

Version: V2.7

Publication date: 16/02/2023

Translation of the original manual

Subject to technical modifications

Copyright © agtatec ag

Table of contents

1	Safety	5
1.1	Presentation of warning signs.....	5
1.2	Intended purpose of use.....	5
1.3	General hazards.....	6
1.4	State of technology.....	8
1.5	Personal protective equipment.....	9
1.6	Spare parts and liability.....	9
2	General information	10
2.1	Purpose and use of the instructions.....	10
2.1.1	Application range.....	10
2.2	Copyright.....	10
2.3	Storage of the manual.....	10
2.4	Product identification.....	10
2.5	Manufacturer agtatec ag.....	10
2.6	Target groups.....	11
2.7	Definition of terms.....	11
3	Specifications	12
3.1	General technical data.....	12
3.2	Power supply data.....	12
3.3	Door opening speed.....	12
3.4	Environmental conditions.....	12
4	Operation	13
4.1	Selection of operating modes (BDE-D).....	13
4.2	Selection of special functions.....	14
4.3	Locking/unlocking the control unit via the keypad.....	14
4.4	Locking the control unit with a key (option).....	15
4.5	Selection of operating modes (BDE-M).....	16
5	Inspection and maintenance	17
5.1	Functions and safety check.....	17
5.1.1	General remarks.....	17
5.1.2	Monthly inspection work to be carried out by the operating company.....	18
5.2	Operator duties.....	19
5.3	Commissioned technician.....	20
5.4	Legal principle.....	20
5.5	Extent of the inspection.....	21
5.6	Requirements for documentation.....	21
5.7	Maintenance and regular inspection.....	21
5.8	Door care.....	21
5.9	Recommended and planned spare- and wear parts.....	22
5.10	Conclusion and reporting.....	22
5.11	Service - Checklist.....	23
6	Malfunctions	25
6.1	Behavior in event of faults.....	25
6.1.1	Display on the control unit.....	25
6.1.2	Resetting the control module.....	25
6.1.3	Control unit BDE-D does not react.....	26
6.2	Error display and troubleshooting.....	26
6.3	Possible troubleshooting.....	26
6.4	Manual opening (without manual unlocking device).....	27

Table of contents

6.5	Manual closing	28
6.5.1	Manual closing - step 1	28
6.5.2	Manual closing - step 2	29
6.6	Operating door in emergency.....	30
6.7	Emergency opening with current supply	30
6.8	Emergency opening in case of power failure with a back-up battery (optional).....	30
6.9	Emergency operating using Bowden cable (Option).....	30
6.9.1	Available versions	30
6.9.2	Procedure for an emergency opening.....	31
6.9.3	Closing and locking the door.....	31
7	Taking out of service and disposal	32
7.1	Decommissioning.....	32
7.2	Dismantling and disposal	32

1 Safety

1.1 Presentation of warning signs

Various symbols are used in this guide for easier understanding:



NOTICE

Useful advice and information to ensure correct and efficient workflow of the system.



IMPORTANT

Specific details which are essential for trouble-free operation of the system.



IMPORTANT

Important details which must be read for proper function of the system.



CAUTION

Against a potential hazardous situation that can lead to minor personal injury and property damage.



WARNING

Against a latent hazardous situation that can lead to severe injuries or death and cause substantial property damage.



DANGER

Against an imminent hazardous situation that can lead to severe injury or death.



DANGER

Against an imminent or latent hazardous situation that could lead to electric shock and cause serious injury or death.

1.2 Intended purpose of use

The system is designed exclusively for use as a pedestrian passage. The installation must only occur in dry areas. If there are deviations then proper waterproofing and water drains will be required on site.

Any other application or use beyond this purpose is not considered to be an intended purpose. The manufacturer bears no liability for any resulting damage; the operator alone shall bear the associated risk.

The intended purpose also includes observation of the operating conditions specified by the manufacturer, in addition to regular care, maintenance and repair.

Interventions in or alterations to the installation performed by non-authorized maintenance technicians exclude the manufacturer's liability for consequential damages.



NOTICE

The operation of an automatic door in combination with a wicket door may only take place if the latter is in a secured position.

1 Safety

1.3 General hazards

The following section lists hazards that can be caused by the system even when used as intended. To reduce the risk of malfunction, damage to property or injury to persons and to avoid dangerous situations, the safety instructions listed here must be observed.

The specific safety instructions in the other sections of this manual must also be observed.



IMPORTANT

The country-specific regulations must be observed and complied with!



WARNING

Serious injuries and major property damage.

Incorrect mounting can lead to serious injuries and/or cause major damage to property.

- a) Observe and comply with all important instructions regarding safe assembly.



IMPORTANT

To avoid malfunctions, moving objects such as flags or parts of plants must not be allowed to enter the detection range of the sensors.



NOTICE

The installation must be inspected during the function and safety check for imbalance and signs of wear or damage to cables, springs and fastening parts.

The equipment must NOT be used if repair or adjustment work needs to be carried out.



NOTICE

Checking, repairs, service, maintenance and cleaning may only be carried out when the system is at a standstill and switched off. Before work can be started, persons must be barred from the system and the danger area.



CAUTION

Risk of malfunctions, material damage or injury due to improper settings!

- a) Improper settings can lead to malfunctions, material damage or personal injury.
 - ⇒ Do not disconnect the system from the power supply overnight.
 - ⇒ Settings should only be made by personnel qualified to do so.
 - ⇒ Do not disassemble, put out of operation or manipulate safety devices.
 - ⇒ Have faults rectified by specialist personnel or by personnel qualified to do so.
 - ⇒ Have service and maintenance carried out according to locally applicable regulations or according to a maintenance contract.



CAUTION

Risk of malfunctions, material damage or injuries due to insufficient or missing cleaning or care!

- a) Insufficient or inattentive cleaning or care of the system can lead to malfunctions, damage to property or injury to persons.
 - ⇒ Check the sensors regularly for dirt and clean them if necessary.
 - ⇒ Regularly remove dirt accumulations in the floor rail or under the floor mat.
 - ⇒ Keep the system free from snow and ice.
 - ⇒ Do not use aggressive or caustic cleaning agents.
 - ⇒ Use road salt or loose chippings only conditionally.
 - ⇒ Lay the floor mat without folds and flush with the floor.
 - ⇒ Equipment required for cleaning purposes such as ladders or similar must not be leaned on or attached to the system.



CAUTION

Risk of material damage or injury due to unforeseen opening, closing or turning of the door!

- a) The door can open, close or turn unexpectedly. This may result in damage to property or injury to persons.
 - ⇒ No persons may be present in the opening area of the system.
 - ⇒ Ensure that moving objects such as flags or parts of plants do not enter the detection range of the sensors.
 - ⇒ Do not make any settings on the control unit when the system is in use.
 - ⇒ Have faults rectified immediately by specialist or personnel qualified to do so.
 - ⇒ Remove objects from the opening area.
 - ⇒ Do not disassemble, put out of operation or manipulate safety devices.
 - ⇒ Do not rush through a closing system.



CAUTION

Risk of bruising and severing of limbs!

- a) If the system moves, careless behaviour can lead to serious injuries to limbs or severance of limbs.
 - ⇒ Do not reach in when parts of the system are moving.
 - ⇒ Keep a distance when parts of the system move.
 - ⇒ Do not bump into or touch the system when it is moving.
 - ⇒ Do not open or remove protective covers during operation.
 - ⇒ Do not permanently remove covers from the system.
 - ⇒ Only carry out inspection, service, maintenance and cleaning when the system is stationary and switched off.



CAUTION

Danger of material damage or injury due to non-functioning safety devices!

- a) If safety devices are not functioning, manipulated or put out of operation, there is a risk of damage to property or injuries that can lead to death.
 - ⇒ Never disable or manipulate safety devices.
 - ⇒ Have inspection, service and maintenance of the safety devices carried out according to local regulations or according to a maintenance contract.



CAUTION

Danger of malfunctions, damage to property or risk of injury if used by unauthorised persons!

- a) If unauthorised persons use the system, there is a risk of malfunction, damage to property or injury to persons.
 - ⇒ Children under 8 years of age may only use the system under supervision.
 - ⇒ Children must not play, clean or maintain the system.
 - ⇒ Persons with limited physical, sensory or mental abilities as well as persons with insufficient knowledge or experience may only use the system under supervision or must have received and understood instructions to do so.



DANGER

Danger to life due to electric current!

- a) In case of contact with live parts, there is an immediate danger to life due to electric shock. Damage to or removal of the insulation or individual components can be life-threatening.
 - ⇒ Before starting work (cleaning, maintenance, replacement) on active parts of electrical systems and equipment, ensure that all poles are voltage free and that this is maintained for the duration of the work.
 - ⇒ Keep moisture away from live parts. This can lead to a short circuit.
 - ⇒ Never bridge fuses or put them out of operation.
 - ⇒ Do not connect the power supply until all work has been completed.
 - ⇒ Have work on the electrical system performed by qualified personnel only.



DANGER

Danger to life due to non-functioning safety devices of the fire protection system!

- a) If safety devices of the fire protection system do not function properly, there is a risk of serious or fatal injuries.
 - ⇒ Never disconnect the fire protection system from the power supply overnight.
 - ⇒ Do not disassemble, put out of operation or manipulate safety devices.
 - ⇒ Do not remove safety instructions on the system.
 - ⇒ Never block, hold open or otherwise prevent fire doors from closing.
 - ⇒ Have inspection, service and maintenance of the fire protection system carried out in accordance with locally applicable regulations or according to a maintenance contract.
 - ⇒ Have the fire protection system checked and maintained according to the state of the art.

1.4 State of technology

This system was developed using state of the art technology and officially recognized technical safety regulations. The system, depending on its options and diameter, comply with the requirements of the Machine Guidelines 2006/42/EG as well as EN 16005 and DIN 18650 (D).

Nevertheless, danger may arise if not used as intended.



IMPORTANT

Installation, commissioning, inspection, maintenance and repair work may only be conducted by qualified, trained and authorized technicians.

After commissioning or repair work, fill in the check list and give it to the customer for safe keeping.

We recommend obtaining a service agreement.

1.5 Personal protective equipment

Personal protective equipment is used to protect persons from adverse effects on health. Personnel must wear personal protective equipment during the various work activities on and with the system. Personal protective equipment is explained below:



Hearing protection is used to protect the hearing from noise. As a rule of thumb, hearing protection is compulsory from when normal conversation with other people is no longer possible.



The head protection serves to protect against falling and flying parts and materials. It also protects the head from bumping into hard objects.



Protective goggles protect the eyes from flying parts, dust, splinters or splashes.



Protective gloves are designed to protect hands from friction, abrasions, punctures or serious injury and from burning caused by contacting hot surfaces.



Safety shoes protect the feet from crushing, falling parts and slipping on surfaces. The puncture resistance of the shoes ensures, that pointy objects do not penetrate the foot.



The high-visibility vest is used to make the personnel stand out and therefore to be seen. With improved visibility and attention, the high-visibility vest protects personnel in busy work areas from collisions with vehicles.

Depending on the place of work and the working environment, the protective equipment varies and must be adapted accordingly. In addition to protective equipment for specific work, the work site may require other protective equipment (for example a harness).

In hygiene-protected areas, special or additional requirements of personal protective equipment may be required. These requirements must be considered when choosing personal protective equipment. If there is any uncertainty regarding the choice of personal protective equipment, the safety officer must be consulted at the place of work.

1.6 Spare parts and liability

Reliable and trouble free operation of the door is only guaranteed when using parts that were recommended by the manufacturer. The manufacturer declines any liability for damages resulting from unauthorized modifications to the door or the use of parts that are not permitted.

2 General information

2 General information

2.1 Purpose and use of the instructions

These instructions are an integral part of the system and enable efficient and safe handling of the system. In order to ensure proper functioning, the instructions must be accessible at all times and kept in the immediate area of the system.

Although only the male form has been chosen for reasons of better legibility, the information refers to members of both sexes.

The operator must have read and understood the manual before starting any work. The basic requirement for safe working is to follow the safety instructions and the handling instructions. In addition, the local regulations and safety rules apply.

The manual can be handed over in extracts to instructed personnel who are familiar with the operation of the system.

The illustrations are for basic understanding and may differ from the actual presentation. Specific representations are contained in the drawings.



IMPORTANT

A replacement of the instructions is available from the supplier or on the website.

2.1.1 Application range



NOTICE

System 20 includes the following door drives for which these instructions apply.

STA / TSA 20 or 21 or 22, Thermcord, Safecord

2.2 Copyright

The copyright for these instructions remains with:

agtatec ag

The instructions may not be reproduced, distributed, or used for the purpose of competition without the written consent of agtatec ag.

Infringements shall result in the obligation to pay damages.

2.3 Storage of the manual

After the installation of the system, the instructions should be stored in an accessible and dry place.

2.4 Product identification

The nameplate located on the door provides accurate identification of the product.

2.5 Manufacturer agtatec ag

agtatec ag

Allmendstrasse 24

CH – 8320 Fehraltorf

Switzerland

Phone: +41 44 954 91 91

2.6 Target groups



CAUTION

Risk of injury if personnel are insufficiently qualified!

If unqualified personnel work on the system or are in the danger zone of the system, dangers may arise which can cause serious injuries and considerable damage to property.

- a) All work must be carried out by qualified personnel only.
- b) Keep unqualified personnel away from danger areas.

This operating manual is intended for the target groups listed below:

- Operating entity of the system:
the person who is responsible for the technical maintenance of this system
- Operator of the system:
the person who operates the system every day and has been suitably instructed

2.7 Definition of terms

Term:	Explanation:
System	The term is also used in these instructions as a synonym for the product. Door operators, revolving doors, sliding doors, etc. are referred to as a system. If information in these instructions refers to a specific type, this is shown accordingly in the text.
User	Users are all persons who use the system.
System operator	The respective owner is referred to as the system operator, regardless of whether they operate the system as the owner or pass it on to third parties.
Authorized representative	The authorized representative takes over certain parts of the manufacturer's obligations with regard to fulfilling the requirements of the Machinery Directive. In particular, the authorized representative may also place the system on the market and/or sign EC declarations of incorporation.
Qualified personnel	Qualified personnel are authorized and appropriately trained to perform the following work: <ul style="list-style-type: none"> – Disassembly, Assembly, Commissioning, Operation, Audit, Maintenance, Troubleshooting, Decommissioning The qualified personnel have several years of professional experience in the technical field, e.g. as mechanics or machine fitters. The qualified personnel are aware of the residual risks arising from the installation site and, due to their professional training, knowledge and experience, are able to carry out the work assigned to them and to independently identify and avoid possible danger points.
Manufacturer	The manufacturer is whoever designs and/or builds machinery or incomplete machinery under the scope of the Machinery Directive.
Life phases	All phases of the system's condition and use are referred to as life phases. This applies from the time the system leaves the factory until it is disposed of.
Personnel	All persons who carry out activities on and with the system are referred to as personnel. Personnel can be, for example, the operator, the cleaning staff, or the security staff. The personnel meet the personnel qualifications required by the manufacturer.
Service technician	Experts and specialists or representative authorized by the manufacturer to perform commissioning, maintenance and servicing.

3 Specifications

3 Specifications

3.1 General technical data



NOTICE

Load capacity for lintel installations

The standard guidelines for load capacities on lintel installations can be found in the corresponding chapter.



NOTICE

3 carriages required for door weight per leaf > 90 kg
4 carriages required for door weight per leaf > 125 kg

3.2 Power supply data

	Product line 20		Product line 21		Product line 22
	Standard	RED / DUO	Standard	RED	Standard
Mains voltage	100-240 VAC	100-240 VAC	230 VAC	100-240 VAC	230 VAC
Rated power	90 W	90 W	85 W	90 W	120 W
Fuse protection	4 AT	4 AT	3,15 AT	4 AT	3,15 AT
Standby power consumption*	approx. 25 W for all				

* including sensors, control unit and locking device

3.3 Door opening speed

Door opening speed		
for max. 75% of authorized door weight	D-STA	E-STA
	D-TSA	E-TSA
	0.7 m	0.7 m
	1 sec.	1.5 sec.

3.4 Environmental conditions

Temperature range	From -15 to +50° C
Humidity range	Up to 85% rel. humidity, not condensing
Noise emission	< 45 dB
Protection class	IP20

4 Operation

4.1 Selection of operating modes (BDE-D)

The electronic control unit BDE-D is a user-friendly input/output module to control and customise (optional) the system operation. The backlit LCD display informs about the system status by means of symbols and plain text. Error messages are displayed as text.

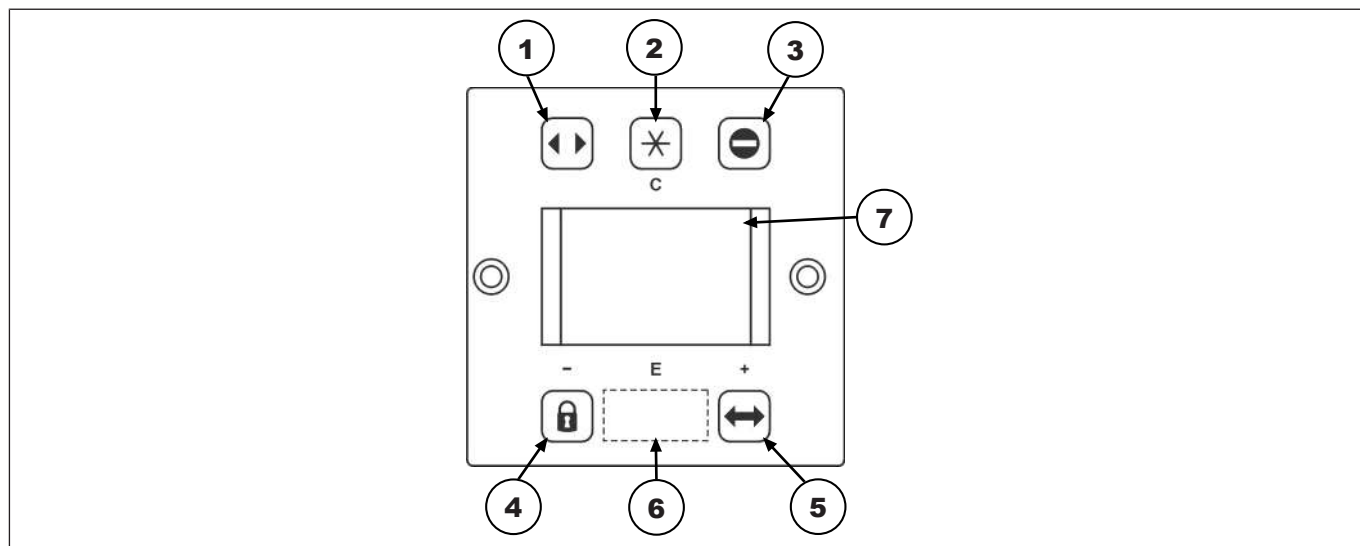

Item	Button	Operating mode	Symbol displayed	Function
1		Continuously open	 Cont. open	– System remains open until another operating mode is selected.
2		Reduced opening width	 Automatic	– Unobstructed access through the system in both directions. – Reduced opening width.
3		One-way	 One-Way	– System opens only in one direction (e.g. for shop closing time).
4		Locked	 Locked	– System is closed and locked (if there is a locking device). – System remains locked even in case of power failure.
5		Automatic	 Automatic	– Unobstructed access through the system in both directions. – Maximum opening with.
6	E 	Menu key		– Access to parameter menu. – Activating the operation lock. – Restart control unit. – Restart hardware BDE-D.
7		LCD display		Provides information about the system status with symbols and plain text.







NOTICE

The reduced opening width is also effective with operating modes (One-way) and (Continuously open).

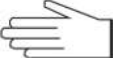
4 Operation

4.2 Selection of special functions

Key operation	Function	Display	Description
	Manual mode	 Manual	<ul style="list-style-type: none"> – Press key twice. – System opens/stops on 2nd key stroke. – System can be operated manually. Back to another operating mode. <ul style="list-style-type: none"> – Activation of the selected key (e.g. Automatic).
	Manual mode	 Manual	<ul style="list-style-type: none"> – Press key for 2 seconds. – System can be operated manually. Back to another operating mode. <ul style="list-style-type: none"> – Activation of the selected key (e.g. Automatic).
	Single opening	 Locked	<ul style="list-style-type: none"> – System is closed and locked. – 1 keystroke unlocks the system (if available). – An opening/closing cycle is performed. – Once closed, system locks again.

4.3 Locking/unlocking the control unit via the keypad



IMPORTANT

The locking of an escape route door is not permitted according to the standard. The function of an escape route door would no longer be possible.





In order to prevent accidental locking of the doors during the use of the building, the choice of the operating mode for emergency exits must be protected according to the standard DIN EN 16005.

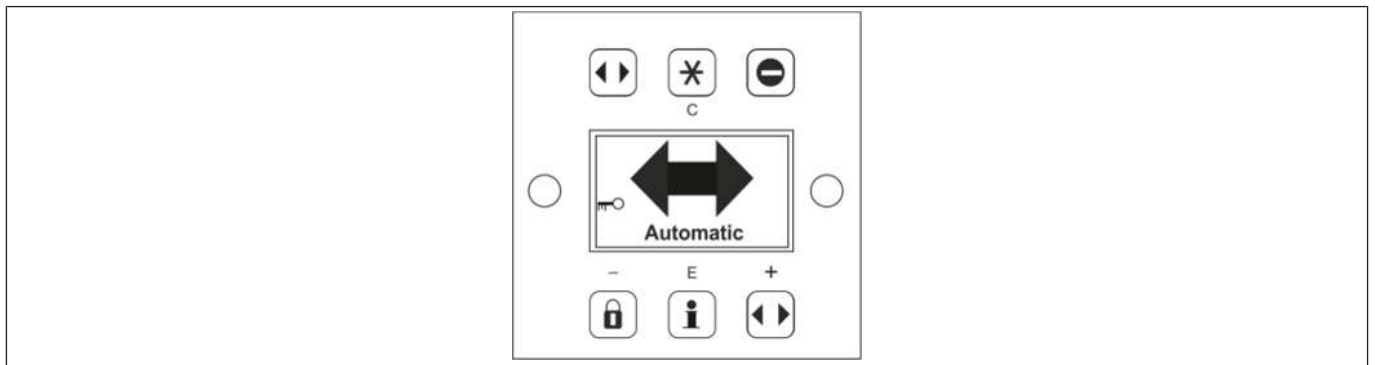



It is the responsibility of the operator of the automatic door with escape route function to lock the control unit in the "Automatic" position while the building is in use.

If the "Locked" operating mode is present, it must be protected with an access code so that only authorized personnel can set another operating mode.



Locking the control unit

Key sequence	Display	Description
  	 Automatic	<ul style="list-style-type: none"> – The control panel is locked. – The locked state of the BDE-D is shown on the display. – Unwanted manipulation of the control unit is made more difficult.

Unlocking the control unit				
Key sequence			Display	Description
			 Automatic	<ul style="list-style-type: none"> - The control panel is unlocked. - The unlocked state of the BDE-D is shown on the display. - Free selection of operating modes and special functions is possible.



NOTICE

The system remains in the previously selected operating mode.

4.4 Locking the control unit with a key (option)



IMPORTANT

The locking of an escape route door is not permitted according to the standard. The function of an escape route door would no longer be possible.

In order to prevent accidental locking of the doors during the use of the building, the choice of the operating mode for emergency exits must be protected according to the standard DIN EN 16005.

It is the responsibility of the operator of the automatic door with escape route function to lock the control unit in the "Automatic" position while the building is in use.

The BDE-D operating unit can be effectively protected against unauthorized adjustment of the operating mode via an external operating lock.



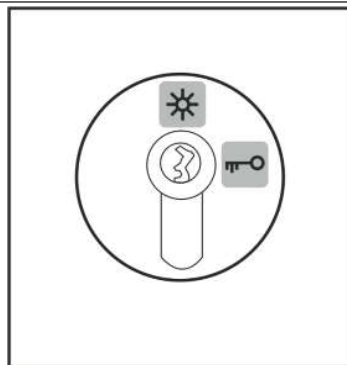

If the "Locked" operating mode is present, it must be protected with a key switch so that only authorized personnel can set a different operating mode.

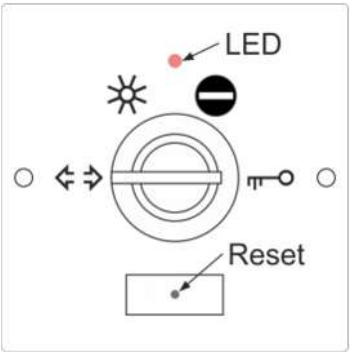

4 Operation

4.5 Selection of operating modes (BDE-M)

 <p>The diagram shows a circular key switch with four positions: a sun symbol (Automatic mode), a double-headed arrow (Continuously open and manual operation), a vertical bar (One-Way), and a key symbol (Locked). An LED is located above the key symbol, and a small hole labeled 'Reset' is located below the key symbol.</p>	<p>The BDE-M mechanical operating unit is equipped with a key switch. This key switch can be used to set the various operating modes. The key switch can be removed in any position.</p> <p>Operating display:</p> <ul style="list-style-type: none"> – The LED lights up when mains or battery voltage is present. <p>Perform reset:</p> <ul style="list-style-type: none"> – This hidden button is operated by means of an approx. 25 mm long paper clip. – For this purpose there is a small hole in the middle of the logo. – If the key is pressed for approx. 5 seconds, the controller is restarted (software reset). The saved settings are retained.
---------------------------------------------------------------------------------------------------------------------------------------------------------------------------------------------------------------------------------------------------------------------------------------------------------------------------------------------------------------------------------------------------------------------	-----------------------------------------------------------------------------------------------------------------------------------------------------------------------------------------------------------------------------------------------------------------------------------------------------------------------------------------------------------------------------------------------------------------------------------------------------------------------------------------------------------------------------------------------------------------------------------------------------------------------------------------------------------------------------------------------------------------------------

Key	Operating mode	Function
	Automatic mode with total opening width	This operating mode corresponds to standard operation. Activation of a triggering device (e.g. RIC 290, RAD 290) opens the door. After the hold-open time has elapsed, the door closes again.
	Continuously open and manual operation	Door opens and remains in the open position. It can then be moved manually.
	One-Way	The door opens only by activating the triggering element located on the inside of the door or by an optional key swing contact (SSK).
	Locked	<p>The door is automatically locked after it has been closed. Only with the key swing contact (SSK) can an opening be triggered with the last valid opening width.</p> <p>Caution:</p> <p>In the event of interrupted power, door opening in the locked state, without an additional battery or without manual release, is no longer guaranteed!</p>

5 Inspection and maintenance

Regular inspection and maintenance of the system by trained and authorized personal from the manufacturer, is the best guarantee for long life and trouble-free secure operation.

These control and maintenance operations are required at regular intervals, following the manufacturer's instructions and the relevant legal requirements.

5.1 Functions and safety check

5.1.1 General remarks



DANGER

Danger to life due to electric current!

- a) In case of contact with live parts, there is an immediate danger to life due to electric shock. Damage to or removal of the insulation or individual components can be life-threatening.
 - ⇒ Before starting work (cleaning, maintenance, replacement) on active parts of electrical systems and equipment, ensure that all poles are voltage free and that this is maintained for the duration of the work.
 - ⇒ Keep moisture away from live parts. This can lead to a short circuit.
 - ⇒ Never bridge fuses or put them out of operation.
 - ⇒ Do not connect the power supply until all work has been completed.
 - ⇒ Have work on the electrical system performed by qualified personnel only.



IMPORTANT

Specific checks and maintenance may only be carried out by a specialist or a person trained for this purpose. The authorization of these persons is carried out exclusively by the manufacturer. The scope, result and time of the periodic inspections and maintenance must be recorded in an inspection book and a checklist. These documents must be kept by the operator.

According to current legislation, the operator of an automatic door system is responsible for its maintenance and safety.

With the care of the installation by the operator, accidents or defects can be avoided.

Testing

Type of test	Action
Visual inspection	Check door leaves, guides, bearings, limiting devices, sensors, and the securing of crushing and shearing points for damage.
Mechanical inspection	Check fastenings for tight fit.
Safety check (exit and escape routes)	Check sensors, safety devices, and monitoring devices for tight fit and damage.
Function testing	Check functioning of switches, operators, controllers, power or energy storage devices, and sensors. Also check the adjustment of the safety devices and the setting of all movement sequences including the end points.
Test run	Final overall review is carried out.

Servicing

Type of servicing	Action
Adjustment and cleaning	Clean and adjust bearings, sliding points, and power transmission. Check relevant fastening screws and retighten if necessary.

For documentation and information purposes, the testing and servicing work as well as the condition of the system are recorded in a test log book. The test log book must be kept for at least one year or until the next testing/servicing.

5 Inspection and maintenance



IMPORTANT

The testing and/or servicing interval according to the manufacturer's specification is at least 1 to 2 times a year.



IMPORTANT

The recommended and planned spare and wear parts can be requested from your service center.

5.1.2 Monthly inspection work to be carried out by the operating company

Monthly control and maintenance of individual elements by the operator requires little time and serves the reliable function, increased service life and operational safety of the system.

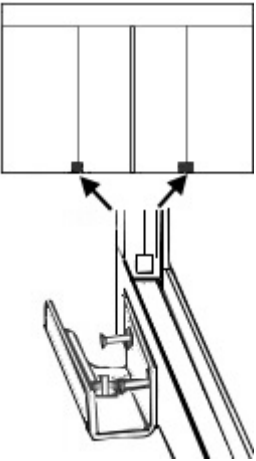
Test / inspection	Procedure	Expected result
Motion detector	<ul style="list-style-type: none"> – Approach the door at normal speed (from the inside and outside). – If necessary, clean the sensors (motion detectors), in particular the external sensor(s). – Note that steaming up of the sensor, for instance due to warm, moist indoor air escaping and condensing on the colder external motion sensor, can prevent the door from closing. Therefore, ensure that the indoor air is dehumidified or wipe the external sensor dry if necessary. 	<ul style="list-style-type: none"> – The sensor must cover the entire passage width. – Door opening takes place at an early stage and at an appropriate speed, so that unhindered passage is possible.
Door leaf / side panels	<ul style="list-style-type: none"> – Check the condition of the panes. – Check the condition of the gaskets / profiles. 	<ul style="list-style-type: none"> – No damaged panes. – No gaskets torn out (energy loss). – The door is the "business card" of your company. Make sure it is in perfect condition.
Door leaf guides 	<ul style="list-style-type: none"> – Check the door leaf guides. – Under certain circumstances, these may be damaged by bumping (e.g. by shopping carts). – Door leaf guides can show exceptional signs of wear due to intensive operation as well as exposure to dirt. 	<ul style="list-style-type: none"> – Door leaf must be properly guided. – Lower as well as vertical door profiles do not show any scratch marks. – Door leaf guide must not develop any unusual noises when opening/closing.

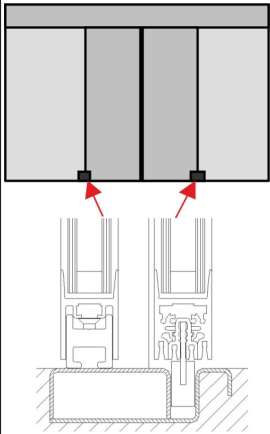
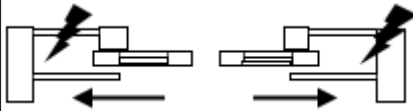
Test / inspection	Procedure	Expected result
<p>Continuous floor guide</p> 	<ul style="list-style-type: none"> – Set the door to manual mode (see chapter "Selecting special functions"). – Clean all guides from dirt, cigarette butts, etc. 	<ul style="list-style-type: none"> – The door leaf must be properly guided. – The movement of the door must not be hindered by dirt.
<p>Drive casing</p>	<ul style="list-style-type: none"> – Check the fastening of the drive casing. 	<ul style="list-style-type: none"> – It must be completely closed and engage securely in the hinges.
<p>Protective leaf (optional - depending on country regulations)</p> 	<ul style="list-style-type: none"> – Check the mechanical condition of the protective leaf. – In particular, check the closing mechanism. 	<ul style="list-style-type: none"> – A protective leaf is to prevent all crushing and shearing points.

5.2 Operator duties

Personal protection requires compliance with the standards and guidelines for publicly accessible facilities.

According to applicable standards and guidelines, automatic door systems must be tested and serviced by qualified persons.

The system operator is responsible for carrying out testing and servicing.



NOTICE

The installation must be inspected during the function and safety check for imbalance and signs of wear or damage to cables, springs and fastening parts. The equipment must NOT be used if repair or adjustment work needs to be carried out.



CAUTION

Risk of malfunctions, material damage or injuries due to insufficient or missing cleaning or care!

- a) Insufficient or inattentive cleaning or care of the system can lead to malfunctions, damage to property or injury to persons.
 - ⇒ Check the sensors regularly for dirt and clean them if necessary.
 - ⇒ Regularly remove dirt accumulations in the floor rail or under the floor mat.
 - ⇒ Keep the system free from snow and ice.
 - ⇒ Do not use aggressive or caustic cleaning agents.
 - ⇒ Use road salt or loose chippings only conditionally.
 - ⇒ Lay the floor mat without folds and flush with the floor.
 - ⇒ Equipment required for cleaning purposes such as ladders or similar must not be leaned on or attached to the system.

5 Inspection and maintenance

Tasks system operator

Task	Personnel	Time of implementation	Entry in the inspection book
Maintenance and cleaning of the sensors for safety and triggering	System operator	Weekly, or as required	No
Function and safety check	System operator	Monthly	No
Function test for fire doors	System operator	Monthly, or according to country-specific standards and guidelines	No

Tasks of qualified person

Task	Personnel	Time of implementation	Entry in the inspection book
Acceptance test	Qualified person	After assembly of the door system ready for operation	Yes
Servicing	Qualified person	1 x annually, or according to country-specific standards and guidelines	Yes
Test (inspection)	Qualified person	1 x annually, or according to country-specific standards and guidelines	Yes
Test (inspection) for door systems in escape routes	Qualified person	2 x annually, or according to country-specific standards and guidelines	Yes
Testing of fire doors	Qualified person	1 x annually, or according to country-specific standards and guidelines	Yes
Testing (inspection) for fire doors	Qualified person	1 x annually, or according to country-specific standards and guidelines	Yes
Servicing for fire doors	Qualified person	1 x annually, or according to country-specific standards and guidelines	Yes

5.3 Commissioned technician

Technicians are people:

- that on the basis of their technical training, knowledge, experience and work, perform their assigned test properly and identify and evaluate potential hazards.
- that have sufficient knowledge in the field of automatic door systems, relevant national safety regulations, accident prevention regulations, directives and generally recognized technical regulations, so they can judge the secure working condition of automatic door systems. These people include, for example, technicians from the manufacturing or supplying company, relevantly experienced, trained personnel authorized by the manufacturer or other persons with appropriate expertise.

Experts must submit their assessment objectively from the standpoint of personal and operational safety without being influenced by other requirements, such as i.e. economic circumstances.

5.4 Legal principle



NOTICE

According to EN 16005 / DIN 18650 / Machinery Directive, the system must be inspected by an expert before initial commissioning and then according to the manufacturer's instructions or at least once a year.

The special significance for personal protection requires compliance with these special regulations.

5.5 Extent of the inspection

The test is carried out according to the manufacturer's test instructions. The result of the test is recorded in a test protocol and recorded in the test logbook.

The inspection usually takes place at the same time as the maintenance of the system.

The inspection also checks whether no changes have been made to the system since the last inspection and whether it meets the current safety requirements.

5.6 Requirements for documentation

Extent, results and dates of the periodic inspections, must be documented and kept by the operator in an Inspection- and Maintenance log book.

The contractor / operator must be informed of the results in writing.

The contractor / operator requires the inspection report (check list) for proof that the periodic inspection was performed and/or as documentation for construction authorities or accident and liability insurances, etc.

5.7 Maintenance and regular inspection

A safety inspection must be carried out before initial start-up and as required, as well as in accordance with the applicable regulations – **but at least twice a year**. We recommend having maintenance carried out at the same time.

A safety-related inspection must be performed by a competent service technician or an authorized partner.

Maintenance due is displayed on the BDE-D operating unit if this function has been activated. The interval for the output of this message is defined by the number of opening cycles and/or after a certain operating time has elapsed.

Regular inspection and maintenance of the equipment by trained personnel, authorized by the manufacturer, provides the best guarantee for a long service life and trouble-free safe operation.

We recommend concluding a service agreement with the service center responsible for your area.



IMPORTANT



A list of the recommended and planned spare and wear parts can either be seen in the appendix or can be requested from your service center.

5.8 Door care

The entire system, including the sensors and safety devices, can be cleaned with a moist cloth and standard commercial cleaners (non-scouring, do not use any solvents). First test the cleaners on a hidden (not easily visible) place. Keep all guides free of dirt.



NOTICE

It is recommended that for carrying out this work, the operating mode  (Locked) or  (Continuously open) be used, so as to avoid possible injuries from unwanted door movements.

5 Inspection and maintenance

5.9 Recommended and planned spare- and wear parts



NOTICE

Depending on the version of the door installed, not all the listed spare and wear parts are installed.

Spare part/Wear part	Interval
* CO48 (Silicon or Rubber)	1 year
* Mechanical power storage device for escape routes in France	
* Pulley CO48	3 years
Battery	3 years
Antistatic brush	3 years
Door leaf guide (plastic)	3 years
Guiding pad	3 years
Safety blocking ball (TOS Break-out system)	5 years
Pulley	In case of wear
Gear belt	In case of wear
Roller, wheel	In case of wear
Counter wheel	In case of wear
Track	In case of wear
Carriage + Track + Rubber damping profile	In case of wear
Belt clamp	In case of wear
Hinge (plastic) for cladding height 200 mm	In case of wear
Locking device (VRR)	In case of wear
Motor	In case of wear
Leaf central seal	In case of wear
Lateral sealing profile	In case of wear
Floor guide rail	In case of wear
Light barrier	In case of wear
Control	In case of failure
BDE Control unit	In case of failure
BBGV Green break glass housing	In case of failure
Others	In case of failure

5.10 Conclusion and reporting

- Fill out all documents, in particular, list defects in the Check list of the Inspection book.
- The customer / operator must be verbally informed of any defects.
- Obtain signature from the customer / operator and service technician (expert).
- Submit the documents to the customer / operator after the on-site acceptance inspection.
- Hand over the keys for the control units.

5.11 Service - Checklist

This work instruction defines the procedure for service and maintenance work at the customer's site.



DANGER

Dangerous electrical voltage!

- a) Risk of death by electric shock
 - ⇒ Do not touch the drive system when the system is turned on.
 - ⇒ Do not spray water into the drive.

No.	Listing of professional maintenance work according to the manufacturer:
1.	Cleaning the drive parts, such as rails, rollers, locks, etc.
2.	Checking the hinges on the drive casing.
3.	Checking the smooth movement of the moving parts.
4.	Adjusting the toothed belt tension.
5.	Adjustment of the door leaves (ground clearance), mechanical and optical control.
6.	Check the protective screen for function and damage (chipped glass edges) as well as for safety, check and readjust, repair or replace if necessary.
7.	Adjusting the counter wheels of the carriages.
8.	Check the running rails, replace immediately if damaged.
9.	Manual and electrical check of the locking device (smooth running of the electromagnets or motor and gears).
10.	Check and adjust emergency opening device or emergency closing device (retighten Bowden cable if necessary).
11.	Visual inspection (tightness, acid crusts) and function test. 5 complete motion cycles of the emergency battery assembly. The battery cells must be replaced for safety reasons if the function test is not passed or the battery cells are older than 4 years.
12.	Check tightness of the drive unit (ATE).
13.	Checking and, if necessary, tightening all cable and plug connections in the drive.
14.	Check that cables are laid according to regulations, take corrective measures if necessary.
15.	Connection of the external software tool.
16.	Check the existing software version of the system control and update if necessary. (The software is constantly updated to meet the latest guidelines and regulations, as well as any new comfort requirements).
17.	Reading out the history (door cycles, error and warning messages) and, in the event of anomalies, preventively searching for causes and taking action.
18.	Control of the individual parameters of the door settings (e.g. hold-open time after key contact, etc.) and, if necessary, new coordination with the customer.
19.	Readjusting the door movement sequences (acceleration, travel speeds, transitions, braking speed).
20.	If required (e.g. if borderline high closing speed is desired), measurement of the dynamic closing forces at the main closing edge with suitable force gauge.
21.	Check door in automatic mode for noiseless running.
22.	Check rubber seals for condition, adjust, replace if necessary.
23.	Check that the anti-static copper or carbon fiber brushes are intact and serving their purpose (grounding). Replace brushes if necessary.
24.	Test the function of the release and safety devices and, if desired, adapt them to the customer's requirements (without violating the safety criteria specified by the regulations).
25.	Checking of (on-site) mounted peripheral devices (e.g. key switch, card reader, time switch, alarm contacts, door monitoring contacts etc.) for function (as far as possible), safety and professional mounting.
26.	Check floor guides/floor rails for mechanical damage, clean, replace if necessary. Check and adjust any floor brushes that may be present and replace if necessary.

5 Inspection and maintenance

No.	Listing of professional maintenance work according to the manufacturer:
27.	Checking the entire system and the relevant environment according to the standard at the time of installation and according to current standards and laws (AStV, AMVO).
28.	Document deviations and/or current recommendations on the work ticket or fill out warnings document.
29.	Review the inspection book (if available). Correct any deficiencies listed there if possible.
30.	Enter the annual safety inspection according to the Work Equipment Ordinance (AMVO) §8.
31.	Renewal of the annual inspection sticker.
32.	Train or retrain operating personnel as required (especially the procedure for manual emergency opening and emergency closing). Hand over the operating instructions on special customer request.
33.	Entry in the plant journal.
34.	Internal control of the maintenance work tickets in relation to identified defects or customer requests.
35.	If applicable, communication with the customer in this regard and possible offer for improvement measures or rectification of defects.
If the door system is equipped with pivoting door leaves and possibly pivoting side panels, the following additional maintenance work must be performed.	
36.	Checking all screws on door leaves and side panels.
37.	Check ball catches on sliding leaves and side panels, readjust, replace if necessary.
38.	Check panic lock knob (rotary knob) for easy movement.
39.	Check for any obstacles in the swivel range.
40.	Clean floor rail.
41.	Check and clean the floor lock (if present) for ease of movement and seating of the striking plate.

6 Malfunctions

6.1 Behavior in event of faults

In the event of an irregularity or malfunction, different displays are shown depending on the connected control unit.



IMPORTANT

If malfunctions that endanger the safety of individuals occur, the system must be turned off. It may not be turned back on until the problem has been resolved by a professional and the danger no longer exists.



NOTICE

If the system performs a slow opening or closing movement, this may be a deliberate, automatic redundancy test (self-test).



6.1.1 Display on the control unit

- Status messages are displayed with status number and text.
- The display changes alternately from white to black.
- After 10 seconds, the telephone number of the relevant service centre is alternately displayed.

6.1.2 Resetting the control module

In some cases, the malfunction may be remedied by restarting the control unit. Please proceed as described below.

- Make sure that the drive cladding is closed and that nobody is obstructing the system or approaching it, thereby triggering an opening of the system.

Button	Selection	Display
		Press > 5 seconds
	No	No
	Yes	Reset control?
		Yes



- Restart of the installation is performed.
- The first movement after a reset occurs at reduced speed.
- If a fault is still displayed on the control unit after resetting, please contact our service centre **stating the error message.**

6 Malfunctions

6.1.3 Control unit BDE-D does not react

If the control panel does not react when the keys are pressed or if no message appears on the display, a reset of the control panel could eliminate the problem.

Proceed as follows:

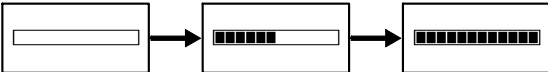
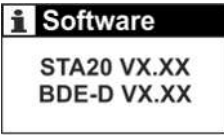
RESET HARDWARE BDE-D	
	Press E key > 12 Sek.
	Display without any message.
	Connecting to control unit.  Connection has been established (example). 

- After resetting, the control panel is again operational.
- If this is not the case, please inform our service centre.

6.2 Error display and troubleshooting





IMPORTANT

Information regarding display texts, status and fault numbers can be found in the book B8A.

6.3 Possible troubleshooting

- Due to the status display, malfunctions can be partially remedied by the user himself.
- If you are not sure, contact the responsible service center.
- Before calling, make a note of the information that can be seen on the display of the BDE-D operating unit. This information gives the technician important hints for a possible troubleshooting.
- If several status messages are active at the same time, they are numbered: e.g. error 1 / 2.
- Pressing the E-button permits to navigate from one error message to the next one.

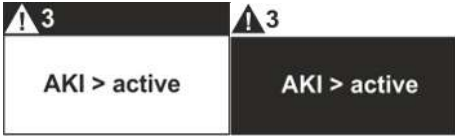
Example:

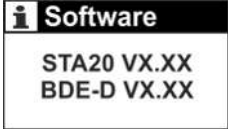
Which information?	Procedure	How displayed? (Example)
Status text and number	– It is automatically displayed on the BDE-D.	
Software-Versions	– Press the following button on the BDE-D for 2 seconds. <div style="text-align: center;"> <small>E</small>  </div>	

6.4 Manual opening (without manual unlocking device)

Initial situation: The door is blocked and locked in de-energized state, in closed position.

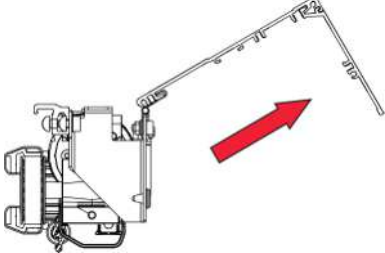
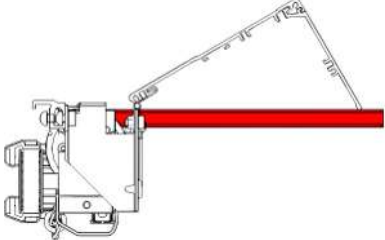
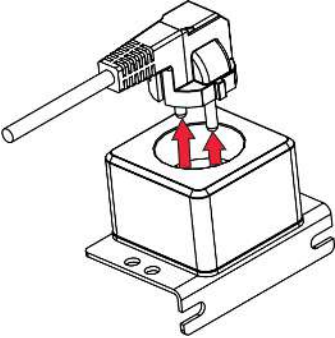
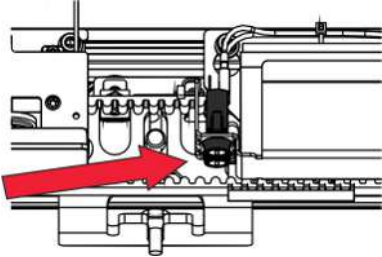
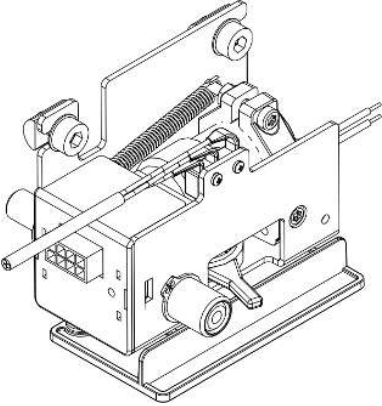
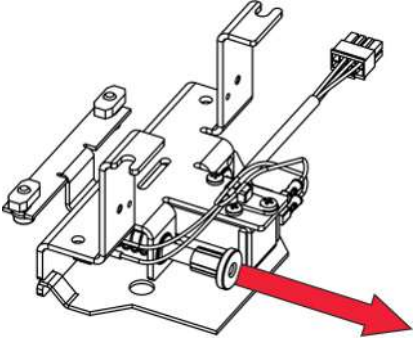
Example: Sequence of manual opening	
	<ul style="list-style-type: none"> – Open the drive casing (swing open). <p>Note: If you pull near the hinges, it makes it easier to open the casing.</p>
	<ul style="list-style-type: none"> – Fold out the red support to fix the drive cover in the open position.
	<ul style="list-style-type: none"> – Disconnect the equipment from the power supply. – The socket is located under the drive casing.
	<p>For systems with integrated emergency battery:</p> <ul style="list-style-type: none"> – In addition, unscrew the battery fuses. – The battery is located under the drive casing.
<p style="text-align: center;">Locking system 20</p>  <p>The lock is provided with an unlocking lever.</p>	<p style="text-align: center;">Locking system 20-200</p>  <p>The lock is provided with an unlocking bolt. By pulling, the door unlocks.</p>

6 Malfunctions

Example: Sequence of manual opening

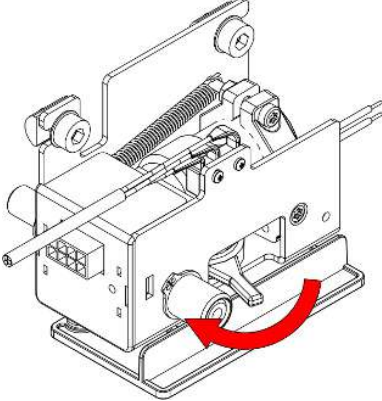
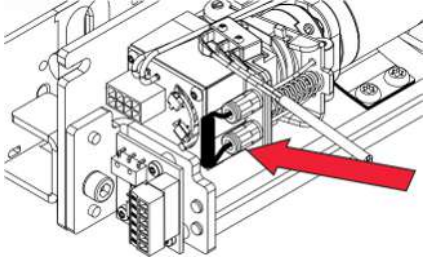
	<ul style="list-style-type: none"> – Actuate the lever clockwise. – The door unlocks and can be pushed open manually.
<p>For multipoint locking (MPV)</p>  <p>The lock is provided with a rope loop.</p>	<ul style="list-style-type: none"> – Pull strongly on the rope loop. – The door unlocks and can be pushed open manually.
<ul style="list-style-type: none"> – Close the drive cover by applying a strong pressure in the area of the hinges. 	

6.5 Manual closing



Initial situation: Power supply is present. Door remains blocked in open position.



NOTICE

Depending on the type of fault, the procedure for closing the door manually varies. Follow the steps described below.

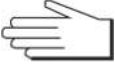
6.5.1 Manual closing - step 1

Key	Function	Display	Description BDE-D
	Manual mode	 Manual	<ul style="list-style-type: none"> – Press key 2 x in succession. – The door can be closed or opened manually. <p>Makeshift door operation (e.g. at low outside temperature)</p>
	Locked	 Locked	<ul style="list-style-type: none"> – Night locking – Press <i>additionally</i> the Locked key. – Push the door manually to the closed position. – Door is closed and locked (if locking device is present). <p>Notify service center. (Phone number is shown on the display)</p>



NOTICE

If the door still cannot be operated and locked manually, perform the steps described below.

6.5.2 Manual closing - step 2

If the attempts to close and lock the door described under "step 1" have remained unsuccessful, it indicates a severe failure. Please proceed as follows:

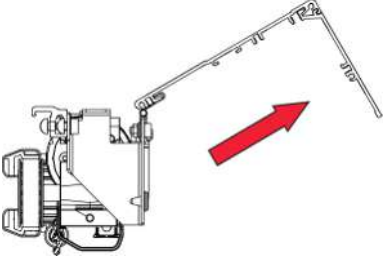
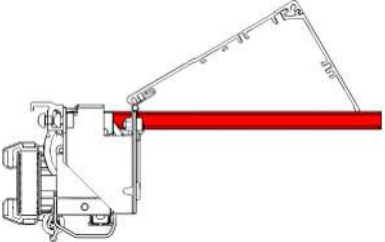
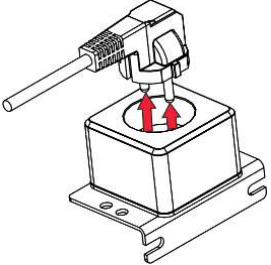
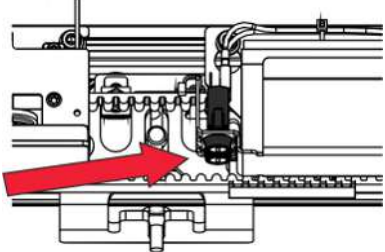
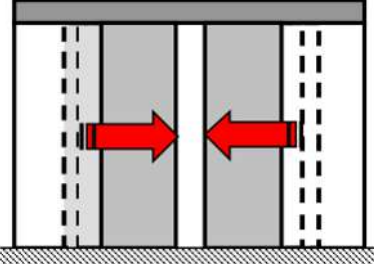
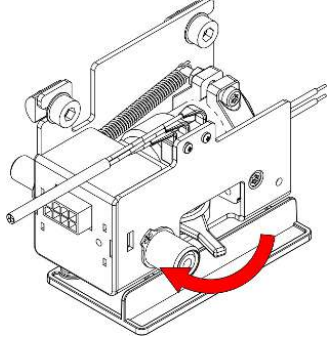
Example: Sequence of manual closing	
	<ul style="list-style-type: none"> – Set the door in manual mode with the control unit (see chapter "Manual closing - step 1"). – Open the drive casing (swing open). <p>Note: If you pull near the hinges, it helps open the casing.</p>
	<ul style="list-style-type: none"> – Fold out the red support to fix the drive cover in the open position.
	<ul style="list-style-type: none"> – Disconnect the equipment from the power supply. – The socket is located under the drive casing.
	<p>For systems with integrated emergency battery:</p> <ul style="list-style-type: none"> – In addition, unscrew the battery fuses. – The battery is located under the drive casing.
	<ul style="list-style-type: none"> – Push the door manually to the closed position.
<p style="text-align: center;">Locking system 20</p> 	<ul style="list-style-type: none"> – Operate the release lever clockwise and hold it in this position so that the door can close completely. – The door locks as soon as you release the unlocking lever.

6 Malfunctions

Example: Sequence of manual closing

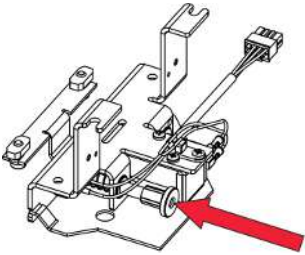
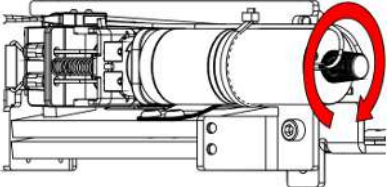
<p>Locking system 20-200</p> 	<ul style="list-style-type: none"> – The door locks when you press the unlocking bolt inwards.
<p>With multipoint locking (MPV)</p> 	<ul style="list-style-type: none"> – Turn the red knob clockwise until you feel resistance and you cannot turn it any further. – Check by hand if the door is really locked. – Leaving the building is possible only through a second exit. <p>Notify service center (Phone number is shown on the display)</p>

6.6 Operating door in emergency

In accordance with country-specific safety regulations (concept of emergency exit, etc.) the doors are fitted with an emergency opening device.

6.7 Emergency opening with current supply

By activating the emergency opening switch (optional), which must be placed beside the installation, the door will open as long as the operating mode Locked has not been selected. In this operating mode the door will remain locked.

To re-start the installation, the emergency opening switch must be reset by hand, either through a rotation or a pulling (different procedures depending on the version of the switch).

6.8 Emergency opening in case of power failure with a back-up battery (optional)

- If a back-up battery is fitted and parametrized as 'Battery operation', all functions of the automatic door will continue to be available.
- In case of a power failure, emergency opening is ensured by a back-up battery that opens the door once (except if the program is set to 'Locked').
- The number of door openings depends mainly on door weight and the battery's charging state.
- The last door operation in case of a weak battery (insufficient capacity) is selectable: 'Open' or 'Close'.
- If the door is in the 'Locked' state, it can be unlocked by means of the key switch/push button (optional).

6.9 Emergency operating using Bowden cable (Option)

This device, available in several versions, is mounted inside and/or outside and allows the unlocking of the door, according to the procedure below.

6.9.1 Available versions

The available versions are illustrated below. They are basically identical in their function.

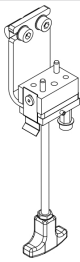
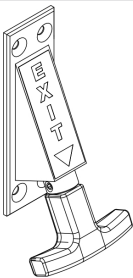
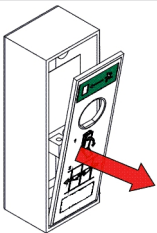
102-020808512	102-020808757	102-014102000
		

6.9.2 Procedure for an emergency opening

Emergency opening

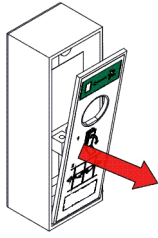

- Open the unlocking flap.
- Pulling the unlocking flap downwards unlocks the door.
- Display on the BDE-D.
→ Error No. 31 / Emergency stop
- The door can be slid open by hand.

6.9.3 Closing and locking the door

Procedure for closing and locking the door

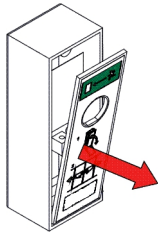

- Activate the emergency opening.
- This causes the locking device to be unlocked.

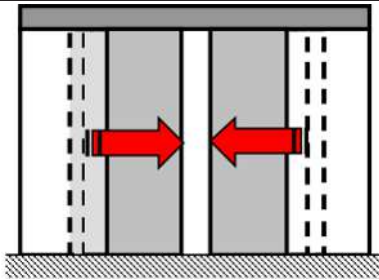

- Slide the door manually into the closed position.
- Keep the door leaves in the closed position.

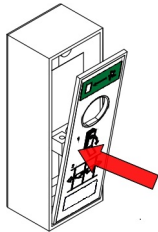

- Close the unlocking flap.
- The door is now locked.

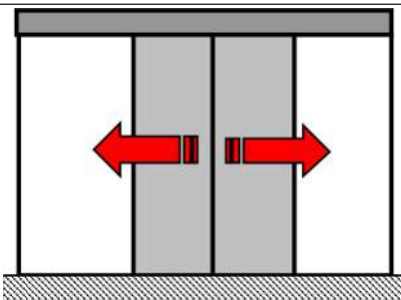

- **Check manually if the door is really locked.**

**NOTICE**

Same procedure for the other operating elements.

7 Taking out of service and disposal

7 Taking out of service and disposal

7.1 Decommissioning

When shutting down or taking out of service, the system is disconnected from the mains supply and any existing battery is unplugged.



NOTICE

After each temporary shutdown a new commissioning must be carried out.

7.2 Dismantling and disposal



IMPORTANT

All machine parts must be sorted by type of material and disposed according to local regulations and guidelines.



NOTICE

The door systems can be completely disassembled in reverse order.

The installation mainly consists of the following materials:

Aluminum:

- Linking profiles
- Gearbox, Drive panel
- Door wing profiles and side profiles
- Various profiles and small parts

Steel / iron parts:

- Stainless steel casing, Floor panel, Box recess for floor installation
- Optional spacer or reinforcement profiles
- Gear components, springs
- Various small parts like fittings, covers, linking parts, etc.

Glass:

- Door wings and side panels

Various electronic and electromechanical components:

- Sensors, control and operator components
- Batteries and rechargeable batteries

Various plastics:

- Rollers
- Cable clips, coupling and linking parts
- Sealing profiles
- Casing of electromechanical components and sensors



Your global partner for entrance solutions